

Champion[®]

The Dishwashing Machine Specialists

PROJECT: _____

ITEM # _____ QTY: _____

MODEL # _____

AIA # _____ SIS # _____

EUCCW FLIGHT PRO SERIES

PRO SERIES FLIGHT 29" CONVEYOR SERIES



Rendered image is for general visual representation only. Please refer to specifications for the latest detailed product information.

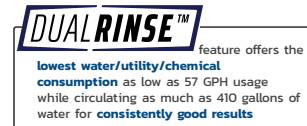

STANDARD FEATURES

- **7" Advanced Touchscreen Control System**
- **Onboard Service Diagnostics** with active user guidance
- **Automated Delime Function**
- **Automated Preventive Maintenance System**
- **Stainless Steel Automatic Drains**
- **Factory Authorized Startup**
- **Energy Star[®] Certified**
- **Exclusive Dual Rinse Technology**
- **All-Purpose 29" Wide Peg Belt**
- **Dish Capacities** up to 15,027 dishes per hour (NSF Listed)
- **Integrated Maintenance Notification Schedule**
- **Automatic Tank Fill**
- **Chemical Dispensing Connection Provisions**
- **Choice Of Tank Heat:** electric, steam coils or direct steam injectors
- **Stainless Steel Booster Heater**
- **Common Hot Water Connection**
- **Common Drain Connection**
- **Common Electrical Connection** (separate connection required for optional electric booster and electric blower-dryer)
- **Single-Point Condensate Connection** (steam heated machines, except for blower-dryer)
- **One Piece Stainless Steel Wash/Rinse Manifolds** easy removal
- **Door Safety Switch**
- **Electric Eye Energy Sentinel** (idle pump shutoff)
- **Heavy Gauge Stainless Steel Construction**
- **Low Water Tank Heat Protection**
- **Push Button Start/Stop Station** – load end
- **Recirculating Flushing Nozzles** – load end with prewash
- **Conveyor Shutoff Shelf** – unload end
- **Stainless Steel Enclosure Panels** – front and ends
- **Vent Fan Control Connection Provision**
- **Hinged Insulated Access Doors**
- **Tank Heat Circuit Breakers** (electric heated machines)



SPECIFIER STATEMENT

Specified unit will be Champion Model PRO Flight 4, 6 or 8 upright 29" conveyor water saver dishwashing machine. Features touchscreen controls, automatic delime, automatic tank fill, automated preventive maintenance, chemical dispensing connection provisions, common water, drain and electrical connections, door safety switch, low water tank heat protection, and rinse saver.

1 year parts and labor warranty.

In the USA:

3765 Champion Blvd, Winston-Salem, NC 27105
Tel: (336) 661-1556 Fax: (336) 661-1979
www.championindustries.com

In Canada:

2674 N. Service Rd., Jordan Station, Ontario, Canada LORISO
Tel: (905) 562-4195 Fax: (905) 562-4618
www.championmoyerdiebel.ca

Right to Left Model

Top View

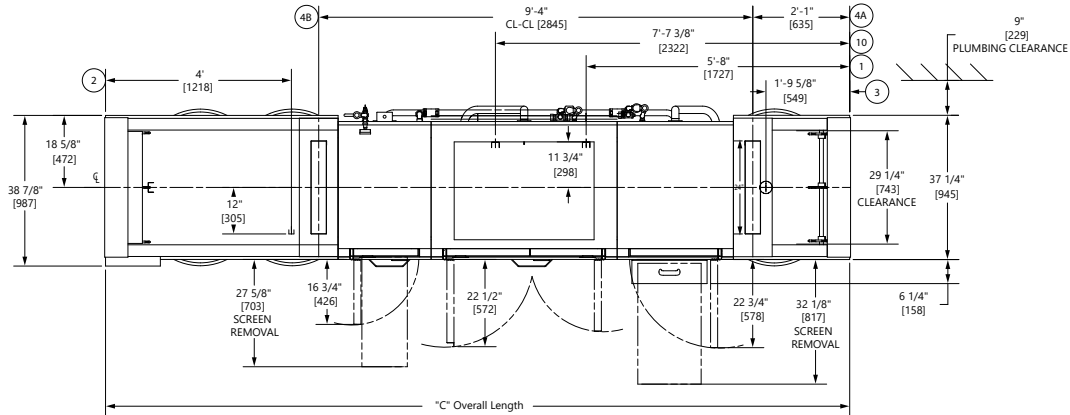

Front View

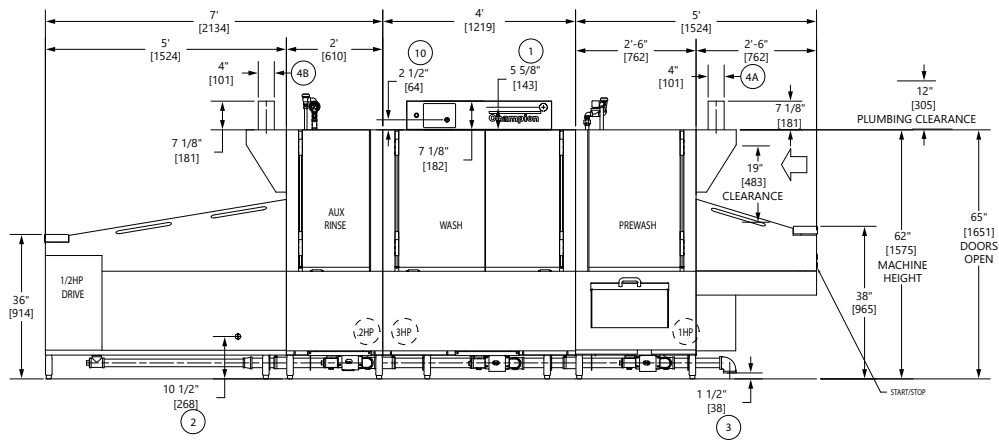

TABLE A - Machine Connection

Machine Only - Electric Heat			
Elec. Specs	Rated Amps	Minimum Supply Ckt. Conductor Ampacity	Maximum Overcurrent Protective Device
208/60/3	172	225	225
240/60/3	148	200	200
480/60/3	74	100	100

Machine - Steam			
Elec. Specs	Rated Amps	Minimum Supply Ckt. Conductor Ampacity	Maximum Overcurrent Protective Device
208/60/3	19	25	25
240/60/3	16	20	20
480/60/3	9	15	15

Notes:

- Load Section (A) Standard 5', contains 30" Prewash
- Prewash also available in a 48" HD section
- Non-standard load section available in 12" increments
- Minimum load length 5' (including 30" prewash)
- Unload Section (B) Standard 5', contains 24" Aux.
- Unload Section available in 12" increments
- Built-in electric booster requires a minimum 5' unload
- Built-in steam booster requires a minimum 6' unload
- Blow dryer section adds 4' to overall length of machine

TABLE B - Booster Connection

40°F / 22°C Rise - 10kW Electric Built-in Booster			
Elec. Specs	Rated Amps	Minimum Supply Ckt. Conductor Ampacity	Maximum Overcurrent Protective Device
208/60/3	28	35	35
240/60/3	24	30	30
480/60/3	12	15	15

70°F / 39°C Rise - 18kW Electric Built-in Booster			
Elec. Specs	Rated Amps	Minimum Supply Ckt. Conductor Ampacity	Maximum Overcurrent Protective Device
208/60/3	50	70	70
240/60/3	44	60	60
480/60/3	22	30	30

Contact Factory for additional voltages.

In the USA: 3765 Champion Blvd, Winston-Salem, NC 27105 | Tel: (336) 661-1556 Fax: (336) 661-1979 | www.championindustries.com

In Canada: 2674 N. Service Rd., Jordan Station, Ontario, Canada LOR1S0 | Tel: (905) 562-4195 Fax: (905) 562-4618 | www.championmoyerdiebel.ca

Right to Left Model

Top View

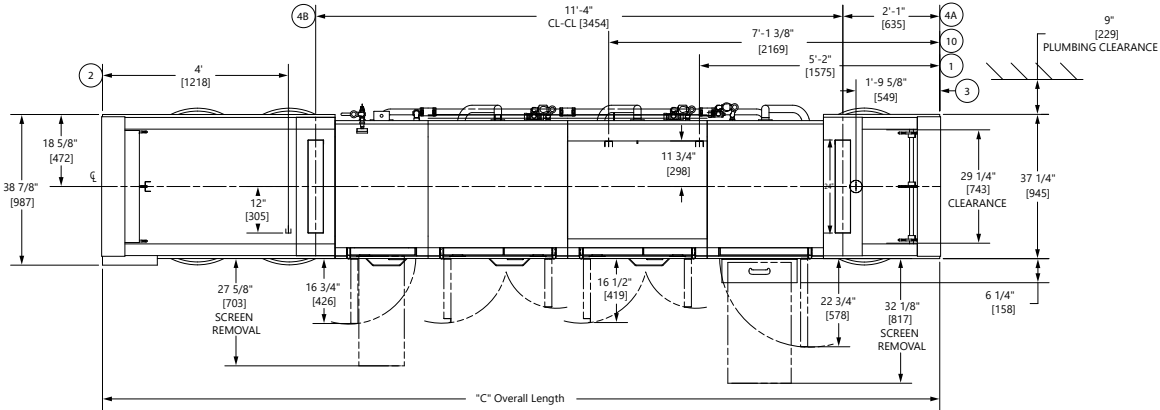

Front View

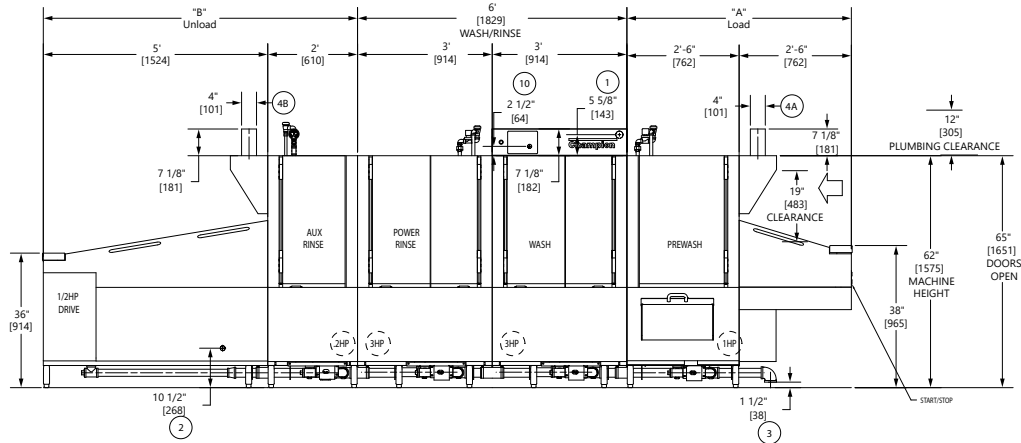

TABLE A - Machine Connection

Machine Only - Electric Heat			
Elec. Specs	Rated Amps	Minimum Supply Ckt. Conductor Ampacity	Maximum Overcurrent Protective Device
208/60/3	181	250	250
240/60/3	156	200	200
480/60/3	78	100	100

Machine - Steam			
Elec. Specs	Rated Amps	Minimum Supply Ckt. Conductor Ampacity	Maximum Overcurrent Protective Device
208/60/3	27	35	35
240/60/3	24	30	30
480/60/3	12	15	15

TABLE B - Booster Connection

40°F / 22°C Rise - 10kW Electric Built-in Booster			
Elec. Specs	Rated Amps	Minimum Supply Ckt. Conductor Ampacity	Maximum Overcurrent Protective Device
208/60/3	28	35	35
240/60/3	24	30	30
480/60/3	12	15	15

70°F / 39°C Rise - 18kW Electric Built-in Booster			
Elec. Specs	Rated Amps	Minimum Supply Ckt. Conductor Ampacity	Maximum Overcurrent Protective Device
208/60/3	50	70	70
240/60/3	44	60	60
480/60/3	22	30	30

Notes:

- Load Section (A) Standard 5', contains 30" Prewash
- Prewash also available in a 48" HD section
- Non-standard load section available in 12" increments
- Minimum load length 5' (including 30" prewash)
- Unload Section (B) Standard 5', contains 24" Aux.
- Unload Section available in 12" increments
- Built-in electric booster requires a minimum 5' unload
- Built-in steam booster requires a minimum 6' unload
- Blow dryer section adds 4' to overall length of machine

Contact Factory for additional voltages.

Right to Left Model

Top View

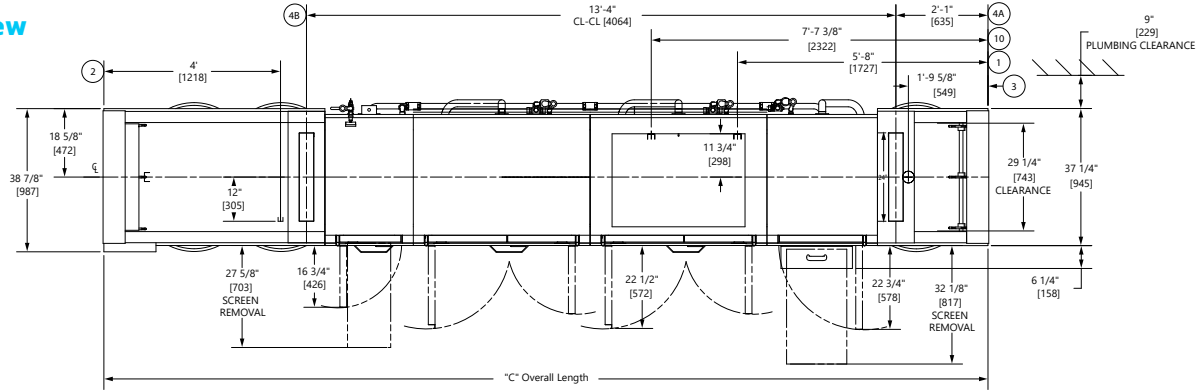

Front View

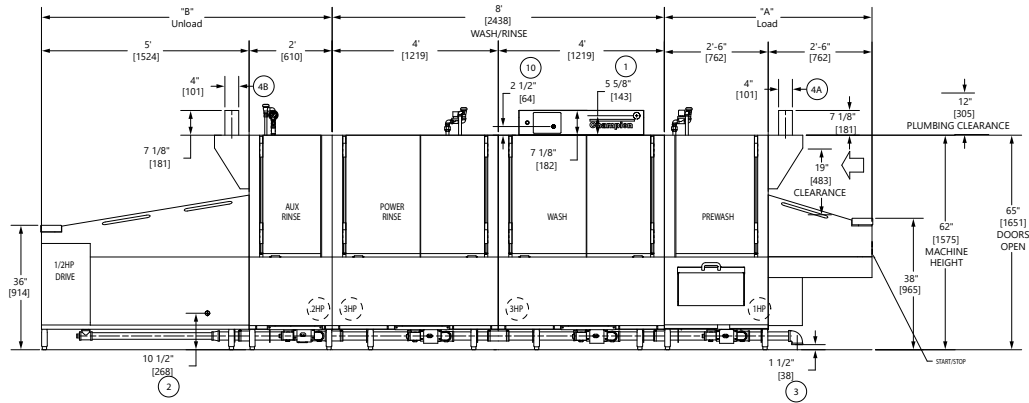

TABLE A - Machine Connection

Machine Only - Electric Heat			
Elec. Specs	Rated Amps	Minimum Supply Ckt. Conductor Ampacity	Maximum Overcurrent Protective Device
208/60/3	181	250	250
240/60/3	156	200	200
480/60/3	78	100	100

Machine - Steam			
Elec. Specs	Rated Amps	Minimum Supply Ckt. Conductor Ampacity	Maximum Overcurrent Protective Device
208/60/3	27	35	35
240/60/3	24	30	30
480/60/3	12	15	15

Notes:

- Load Section (A) Standard 5', contains 30" Prewash
- Prewash also available in a 48" HD section
- Non-standard load section available in 12" increments
- Minimum load length 5' (including 30" prewash)
- Unload Section (B) Standard 5', contains 24" Aux.
- Unload Section available in 12" increments
- Built-in electric booster requires a minimum 5' unload
- Built-in steam booster requires a minimum 6' unload
- Blow dryer section adds 4' to overall length of machine

TABLE B - Booster Connection

40°F / 22°C Rise - 10kW Electric Built-in Booster			
Elec. Specs	Rated Amps	Minimum Supply Ckt. Conductor Ampacity	Maximum Overcurrent Protective Device
208/60/3	28	35	35
240/60/3	24	30	30
480/60/3	12	15	15

70°F / 39°C Rise - 18kW Electric Built-in Booster			
Elec. Specs	Rated Amps	Minimum Supply Ckt. Conductor Ampacity	Maximum Overcurrent Protective Device
208/60/3	50	70	70
240/60/3	44	60	60
480/60/3	22	30	30

Contact Factory for additional voltages.



The Dishwashing Machine Specialists

EUCCW FLIGHT PRO SERIES

PRO SERIES FLIGHT 29" CONVEYOR SERIES

Shipping weight crated: 200 lbs/ft [298 kg/m] Dimensions shown in inches
Height with doors open: 65" [1651]

SPECIFICATIONS

Capacity	EUCCW 4	EUCCW 6	EUCCW 8
Dishes per hr (NSF rated)	9,965	13,445	15,027
Conveyor speed (ft/min)	6.3	8.5	9.5
Motor Horsepower			
Drive	1/2 HP	1/2 HP	1/2 HP
Prewash 30" [762]	1 HP	1 HP	1 HP
Prewash 48" [1219]	3 HP	3 HP	3 HP
Wash	3 HP	3 HP	3 HP
Power Rinse*	N/A	3 HP	3 HP
Auxiliary Rinse	1/5 HP	1/5 HP	1/5 HP
Water Consumption			
Gal. per hr (max. use)	58	57	58
Temperatures °F			
Wash (min.)	160	150	150
Power rinse (min.)*	N/A	160	160
Auxiliary rinse (min.)	165	165	165
Final rinse (min.)	180	180	180
Heating			
Tank Heat	Steam		Electric
Wash Tank	125 lbs/hr		25 kW
Wash Tank (EUCC 4)	225 lbs/hr		45 kW
Rinse Tank	100 lbs/hr		20 kW
Auxiliary rinse	50 lbs/hr		10 kW
Steam booster (lbs/hr required for 40°F rise)	50	50	50
Steam booster (lbs/hr required for 70°F rise)	90	90	90
Electric booster (kW required for 40°F rise)	10	10	10
Electric booster (kW required for 70°F rise)	18	18	18
Venting			
Minimum CFM, load end	300	300	300
Minimum CFM, unload end	800	800	800
With HRU	400	400	400

* EUCCW4 has no power rinse tank

Booster connections may vary. Contact the Factory.

UTILITIES PRO FLIGHT

1	Electrical Connections Contact the Factory for specific machine electrical requirements
2	Hot Water 3/4" NPT 180°F hot water connection (for machine without built-in booster)
3	Drain 2" NPT connection, 62 gpm max flow rate
4	Vents A Load end: 300 CFM 1/4" S.P. B Unload end: 800 CFM 1/4" S.P. With blower-dryer, increase room ventilation by 600 CFM.
5	Ethernet Connection Connection #10 on drawings is for a standard ethernet connection when optional DirectLink connectivity package is specified.

Warning: Plumbing and electrical connections should be made by qualified personnel who will observe all the applicable plumbing, sanitary, and safety codes and the National Electrical Code.

Note: Water Hammer Arrestor (meeting ASSE-1010 standard or equivalent) to be supplied (by others) in common water supply line at service connection.

Venting Notes: Fabricated duct size: 3-7/8" x 15-7/8" (outside dimensions)

Standard Voltages: (Specify choice): 208/60/3, 240/60/3, and 480/60/3. Available in 3-phase only. For non-standard 3-phase voltages, contact the Factory.

Plumbing Notes: Because of the variation in house-supplied water pressure, a water pressure regulating valve (PRV) is needed (water PRV is standard). Steam PRVs may be required for pressure higher than 30 PSI. The PRVs can either be purchased from Champion or obtained locally.

Champion does not endorse using on-demand (tankless) water heating systems, as well as PEX and other plumbing materials that may limit water flow, as these could impair machine performance. For optimal results, we recommend using appropriately sized conventional hot water tanks and standard copper water supply lines that adhere to our specifications. Not following these recommendations may void the manufacturer's warranty.

Water hardness of 3 grains/US Gal (0.83 Imp Gal) – 5.3 Mg/L or less.

In the USA: 3765 Champion Blvd, Winston-Salem, NC 27105 | Tel: (336) 661-1556 Fax: (336) 661-1979 | www.championindustries.com

In Canada: 2674 N. Service Rd., Jordan Station, Ontario, Canada LORISO | Tel: (905) 562-4195 Fax: (905) 562-4618 | www.championmoyerdiebel.ca

OPTIONS & ACCESSORIES

- ❑ Tank heat: electric, steam coil or steam injectors
- ❑ DirectLink connectivity solution 
- ❑ Heat Recovery
- ❑ Boosters heaters - stainless steel (completely inter-plumbed, controls are inter-wired)
 - o Electric: (40°F rise or 70°F rise)
 - o Steam: (40°F rise or 70°F rise)
- ❑ 48" Blower Dryer, electric or steam (add 4' to overall length)
- ❑ Belts: standard peg belt; flat belt; thermal tray belt; silverware belt; belts with upper cross rods, and other select combination belts
- ❑ Start/Stop station, unload end
- ❑ Back panels, stainless steel
- ❑ Cold water thermostat (for prewash)
- ❑ External scrap bucket on wash tank
- ❑ Insulated hoods
- ❑ Motor pumps, 2 or 3 HP optional in lieu of 1 HP on prewash
- ❑ Bumper rail, machine mounted
- ❑ Steam pressure regulating valve (unmounted)
- ❑ Drain water tempering kit (mounted)
- ❑ Lift up or lift out doors
- ❑ Shock arrestor (water)
- ❑ Water softener

Heat Recovery:

Redirects lost condensate to heat using less energy.

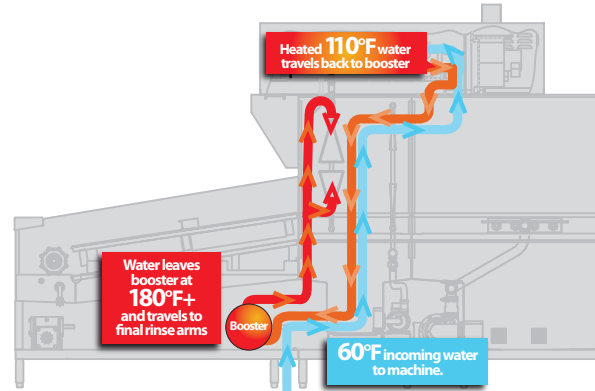

Touchscreen Controller

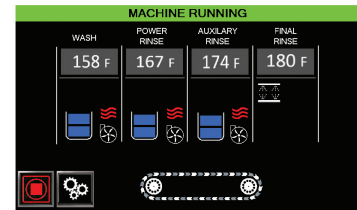

User Guides

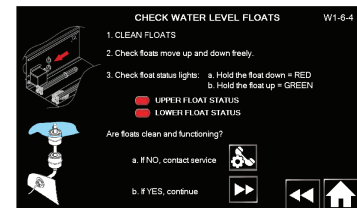

Active Diagnostics

